

Digital Panel Meter SK-EM-20 Instruction Manual



Please ensure that this instruction manual is given to the final user of the instrument.

Preface

Please check that the delivered product is the correct item that you ordered. This instruction manual is for those who will be involved in the wiring, installation, operation and routine maintenance of SK-EM-20, and describes about cautions, mounting, wiring, functions, and operation. Please observe the contents, and always keep the manual close at hand when handling this instrument.

The following headings give a description of matters requiring user attention concerning safety, damage to machines and equipment, additional explanations and commentaries are described under the following headings.

	WARNING	Items concerning matters that may lead to an accident producing human injury or death, if the warning is not observed.
	CAUTION	Items concerning matters that may lead to an accident producing damage to machines or equipment, if the caution is neglected.

Note

Note

Additional explanations and commentaries.

Safety cautions



WARNING

SK-EM-20 is designed for industrial use to control temperature, humidity and other physical values. Do not apply this instrument to other objects in a way that may cause grave effects on human safety.

In using this product, be certain to house it, for example, in a control panel, so that the terminals cannot come into contact with personnel.

Do not take this instrument out of its case or put your hand or any conductor inside the case. Such conduct may lead to an accident that endangers life or causes serious injury due to electric shock.



CAUTION

To avoid damage to the connected equipment, facilities or the product itself due to a fault of the product, safety countermeasure must be taken before usage, such as proper installation of the fuse and the overheating protection device.

An alert symbol is printed on the terminal nameplate attached to the case. It warns not to touch the electrical charging parts when the power is being supplied, so as to avoid the risk of electrical shock.

Install a switch or breaker on the external source power circuit connecting to the source power terminal as a means to shut down the power.

The switch or breaker should be installed adjacent to the instrument in a position that allows the operator easy access.

Regarding the fuse:

Since this instrument has no built-in fuse, make sure to install a fuse in the electric circuit connecting to the source power terminal.

Install the fuse in a position between the switch or breaker, and the instrument and attach it to the L side of the source power terminal.

Fuse Rating: 250V AC 1.0A/Time-lag (T) or Medium Time-lag (M)

The load of voltage and current to be applied to the output terminal (analog output) and the alarm terminal must be within the rated range. If the range is exceeded, the instrument will overheat causing the risk of the instrument being damaged and its life reduced.

As for the rating, please refer to "11. Specification."

The unit connected to the output terminal should conform to the requirements of IEC61010-1.

Do not apply over-rated voltage or current to the input terminal. That will cause the risk of the instrument being damaged and its life reduced.

As for the rating, please refer to "11. Specification."

In case the input type is voltage (mV or V) or current (4 - 20mA), the unit connected to the output terminal should conform to the requirements of IEC61010-1.

Take care to prevent metal or other foreign matter from obstructing the ventilating hole for heat radiation. It will cause damage to the instrument and may even result in fire.

Do not block the ventilating hole. Also avoid dust accumulation. Any rise in temperature or insulation failure may result in a risk of the instrument being damaged and its life reduced. As for the clearance space for installing the instrument, refer to "2-3 External dimensions and panel cutout."

Repeating withstanding tests on voltage, noise, surging may lead to the deterioration of the instrument, so please be careful.

Strictly refrain from remodeling and using the instrument improperly.

It takes 30 minutes to display the correct temperature after applying power to the digital Indicator. (Therefore, turn the power on more than 30 minutes prior to the operation.)

- To ensure safety and maintain the functions of this device, do not disassemble this device. If this device must be disassembled for replacement or repair, contact your dealer.
- This device is designed for mounting on the panel. Only the device mounted on the front of the panel facing outward is of protection class of IP66. Do not use for the device not facing outward or in environment where water or solids in excess of IEC60529 may get inside.

Contents

1. Introduction	3
1-1. Check before use	3
1-2. Notes for use	3
2. Installation and wiring	3
2-1. Installation site (environmental conditions)	3
2-2. Mounting	3
2-3. External dimensions and panel cutout	4
2-4. Wiring	4
2-5. Terminal arrangement	4
3. Names and functions for front panel	5
3-1. Names	5
3-2. Functions	5
4. Measuring range code table	5
5. Error messages	5
6. Instruction for each screen	6
6-1. Screen sequences	6
6-2. Power ON Screen Group	7
6-3. Mode 0 Screen Group	7
6-4. Mode 1 Screen Group	8
7. Alarm output	10
8. Analog output	10
9. Sensor power supply	10
10. Communication	11
10-1. Specification	11
10-2. Connecting with host computer	12
(1) RS-232C	12
(2) RS-485	12
(3) Control of 3-state output	12
10-3. Standard protocol	13
(1) Communication overview	13
(2) Recommended communication format	13
(3) Overview of protocol format	13
(4) Basic format section	13
(5) Text section	14
(6) Read command	15
(7) Write command	15
(8) Response codes	16
(9) No response condition	16
10-4. MODBUS protocol	16
(1) Communication overview	16
(2) Message format	16
(3) Commands of MODBUS ASCII mode	17
(4) Commands of MODBUS RTU mode	19
(5) Function codes	20
(6) No response condition	20
10-5. Communication data address list	20
10-6. ASCII Code Table	21
11. Specification	22
12. Warranty Policy	22

1. Introduction

1-1. Check before use

Although the instrument passes thorough quality checks before shipment, when the instrument is delivered, please confirm the type code number, check the external conditions and the list of accessories to make sure that there is no apparent damage or discrepancy.

Confirmation of the type code

Check the type code printed on the label on the packing case with the following table to confirm that the delivered goods meet your order.

Item	Code	Specifications	
1. Series	SK-EM-20	48 × 96 DIN size Digital Indicator	
2. Input (Note 1)	8	Universal-input • Thermocouple • R.T.D. (Pt100, JPt100) • Voltage (Input impedance 500 kΩ min.) 0 - 10mV DC 0 - 5, 1 - 5, 0 - 10V DC	Refer to "4. Measuring range code table" for details. In case voltage input, scaling/reverse scaling is available. (Note 2)
	4	Current 4 - 20mA DC An external receiving resistor is provided.	Scaling/reverse scaling available (Note 2)
3. Power supply	90-	100 - 240V AC ± 10% (50/60Hz)	
	08-	24V AC (50/60Hz) /DC ±10%	
4. Alarm output (option)	0	Without	
	1	Separate setting/separate output 2-point (a-contact, "COM" used commonly) Contact rating 240V AC 1.5A/resistive load	
5. Analog output or sensor power supply (option) (Note 3)	0	Without	
	3	0 - 10mV DC Output resistance 10Ω	Scaling/reverse scaling available (Within measuring range)
	4	4 - 20mA DC Load resistance 300Ω max.	
	6	0 - 10V DC Load current 1mA max.	
8	Sensor power supply 24V±3V DC 25mA max.		
6. Communication function (option)	0	Without	
	5	RS-485: standard protocol / MODBUS	
	7	RS-232C: standard protocol / MODBUS	
7. Display (11-segment LED)	0	11-segment red LED	
	1	11-segment red and white LED's	
8. Remarks	0	Without	
	9	With	

Note 1 The instrument supports full universal input; however please select one of two codes, as an external receiving resistor (250Ω) is supplied for current input. If no external receiving resistor is required, select code 8.

Note 2 Scaling range: -1999 - 9999 digit
Span: 10 - 10000 digit

Note 3 When the 08 power supply code (24V AC/DC) is selected, the sensor power supply cannot be selected.

Accessory list check

- SK-EM-20 Digital Panel Meter 1 unit
- Instruction Manual (Basic Version) 1 copy
- Unit label seal 1 sheet
- Termination Resistor (When selecting Communication option RS-485) 1 pc.

Note Contact us or our distributors via email for any problems about the product, accessories or related items.

1-2. Notes for use

Avoid operating the front panel keys with hard or sharp objects. Lightly touch the operating keys with your fingertips for operation.

- When cleaning, do not use a solvent such as a thinner. Wipe the instrument with a dry cloth lightly.

2. Installation and wiring

2-1. Installation site (environmental conditions)

 CAUTION
Do not install the instrument in such environmental conditions as those listed below. Otherwise, damage may be caused to the instrument, even resulting in fire. <ul style="list-style-type: none"> • Flammable or corrosive gas, oil soot or dust that deteriorates the insulation is generated or abundant. • Ambient temperature is below -10°C or above 50°C. • Ambient humidity is higher than 90% RH, or below dew point. • Strong vibrations or impacts are generated or transferred. • High-voltage power lines exist in the neighborhood, or induction interference. • Exposure to direct sunlight or dew drops. • The elevation is above 2000m. • Outdoor

Note The environmental conditions fall under transient over voltage category II of IEC 60664, and the pollution degree is "2".

2-2. Mounting

Cut a fitting hole by referring to the panel cutout dimensions in section 2-3. The applicable thickness of the panel is 1.0 - 4.0mm.

Insert the indicator into the hole from the front of the panel, as it has catching claws to fix it in position.

Note

- As SK-EM-20 is a panel installation type indicator, use it by mounting on a panel.
- Be sure to install this product with the attached gasket. Failure to do so could result in electric shock. After wiring, do not touch terminal elements or other charged parts. Failure to do so could result in electric shock.

2-3. External dimensions and panel cutout

External dimensions

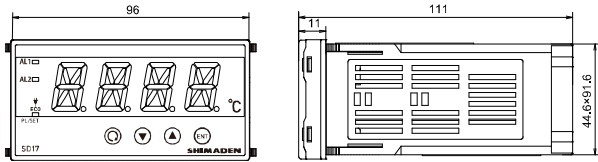

Unit: mm

Panel cutout

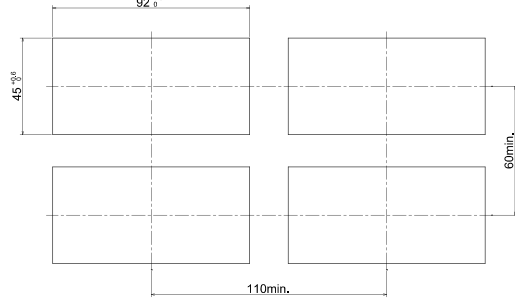

Unit: mm

2-4. Wiring

WARNING

- When wiring the unit, be sure to cut the power supply OFF, or there will be a risk of electric shock.
- Make sure the protective conductor terminal (⊕) is grounded. Otherwise, a serious electric shock may result.
- After completing the wiring, do not touch the terminals and electrically charged parts while the power is ON.

- Make wiring according to the layout in "2-5. Terminal arrangement."
- Use ring tongue terminals of 7mm or narrower width to meet M3.5 screws.

In case of thermocouple input, use a compensation wire with the type of thermocouple selected. The external resistance should be 100Ω or less.

- In case of R.T.D. input, the resistance value per lead wire should be 5Ω or less, and all three wires should have the same resistance value.
- Avoid arranging the input signal line to pass through the same conduit or duct with high-voltage power lines.
- The shield wire (one-point grounding) is effective to eliminate electrostatic induction noises.
- An effective way to eliminate the magnetic induction noises is to twist the input wire in short and equal intervals.
- For the source power connection, use a wire or cable having a cross-section of 1mm² or larger, and a performance capacity equivalent to 600V vinyl insulation wire.
- The grounding wire should have a cross-section of 2mm² or larger, and the grounding work should ensure a ground resistance of 100Ω or less.
- The symbol ⊕ expresses the functional earth terminal. Please connect it to the ground as much as possible to avoid the adverse impact from noise.
- Counter measure against lightning surge will be required for signal line over 30m.
- Screw the terminal connection securely. Tightening torque 1.1 Nm (11kgf cm)

Noise filter

In case the instruments are affected by the power supply noise, install a noise filter to avoid operational errors. Mount the noise filter on the grounded panel and connect the noise filter output and the power supply terminal of the indicator with the minimum possible distance.

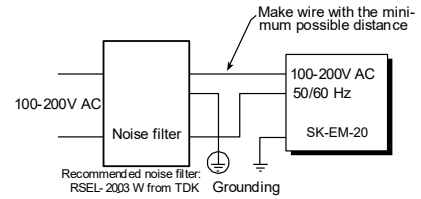

2-5. Terminal arrangement

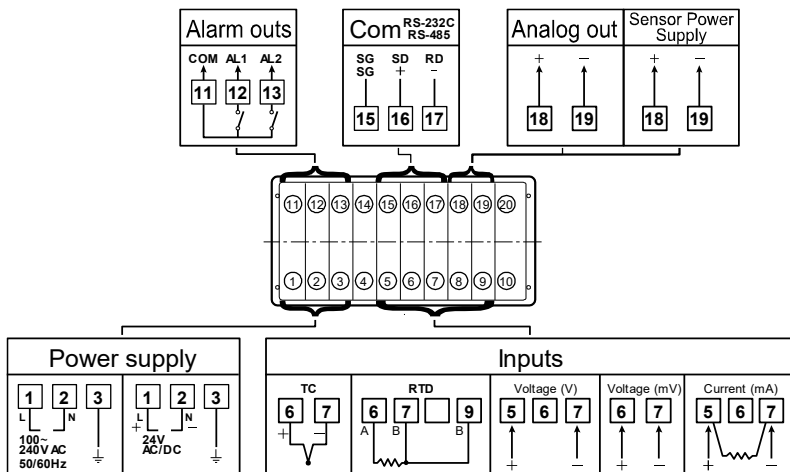

Note Do not connect other than the specified input type to terminal.

3. Names and functions for front panel

3-1. Names

Front panel

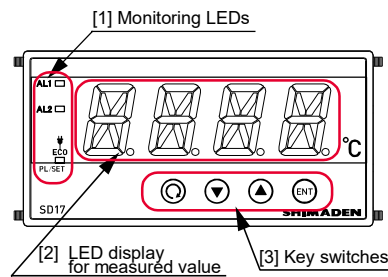

3-2. Functions

[1] Monitoring LEDs

- AL1 (Alarm 1) output monitoring LED (red)
The LED lights when the assigned alarm is ON.
- AL2 (Alarm 2) output monitoring LED (red)
The LED lights when the assigned alarm is ON.
- PL/SET (parameter setting) monitoring LED (green)
The LED lights when the screen displayed is not the basic screen (0-0).
The LED lights flash when it is the screen-saver feature.

[2] LED display for measured value (red,white (option))

- The current PV value is displayed on the basic screen (0-0).
- The type of parameters is displayed on each parameter display screen.
- The set value is displayed on each parameter setting screen.

[3] Key switches

	Parameter key <ul style="list-style-type: none"> • On a display screen, shifts the screen to the next. • Switches from Mode 0 screen group/Mode 1 screen group to Mode 1 screen group/Mode 0 screen group. By pressing this key for two seconds or longer on screen 0-0 or screen 1-0, shifts to the screen 1-0 or to the screen 0-0 respectively.
	Down key <ul style="list-style-type: none"> • On a setting screen, decrements the value. The last digit decimal point blinks until the value is registered by pressing the Entry key.
	Up key <ul style="list-style-type: none"> • On a setting screen, increments the value. The last digit decimal point blinks until the value is registered by pressing the Entry key.
	Entry key <ul style="list-style-type: none"> • On a setting screen, registers the value that is modified by the Up/Down key. The last digit of the decimal point blinks until this registration by pressing the Entry key. • Shifts between a display screen and the setting screen. In this case, the light of the last digit of decimal point goes out.

4. Measuring range code table

Input type		Code	Measuring range (°C)	Measuring range (°F)	Note	
Universal Input (Note 1)	Thermocouple	B	01	0 - 1800	0 - 3300	Note 2
		R	02	0 - 1700	0 - 3100	
		S	03	0 - 1700	0 - 3100	
		K	04	-199.9 - 800.0	-300 - 1500	
			05	0 - 1200	0 - 2200	
		E	06	0 - 700	0 - 1300	
		J	07	0 - 600	0 - 1100	
		T	08	-199.9 - 300.0	-300 - 600	Note 3
		N	09	0 - 1300	0 - 2300	
		U	10	-199.9 - 300.0	-300 - 600	Note 3
		L	11	0 - 600	0 - 1100	
	C(WRe5-26)	12	0 - 2300	0 - 4200		
	R.T.D	Pt	31	-199.9 - 600.0	-300 - 1100	Note 4
			32	-100.0 - 100.0	-150.0 - 200.0	
JPt		33	-199.9 - 500.0	-300 - 1000	Note 4	
Voltage	0 - 10mV	71	0.0 - 100.0 Scaling available Scaling range : -1999 - 9999 digit Span : 10 - 10000 digit			
	0 - 5V	81				
	1 - 5V	82				
	0 - 10V	83				
Current	4 - 20mA	95				

Note 1 In case universal input type is selected, K (Code 05, 0 - 1200°C) is set at factory default.

Note 2 The accuracy of 400°C or below 752°F of thermocouple B is not guaranteed.

Note 3 The accuracy of thermocouple T or U is $\pm(0.5\%FS+1\text{digit})$ at above -100°C and 0°C or below, and $\pm(1\%FS+1\text{digit})$ at -100°C or below.

Note 4 In case of Pt (Code 31) or JPt (Code 33), scale over occurs at -240.0°C (-400°F).

5. Error messages

One of the following error messages is displayed on the basic screen (0-0):

HHHH	When the thermocouple or A of R.T.D. is burnt out. Also indicated when the PV value exceeds the higher-limit of the measuring range by about 10%
LLLL	When the B of R.T.D. (terminal No.7) is burnt out. When the PV value is below the lower-limit of the measuring range by about 10%, for such a reason as the reverse polarity of the input wiring type.
b---	When the B of the R.T.D. (terminal No.9) is burnt out, or two or more wires of A, B, B are broken.
CJHH	When the cold junction (CJ) is abnormal on the higher side in the thermocouple input.
CJLL	When the cold junction (CJ) is abnormal on the lower side in the thermocouple input.

6. Instruction for each screen

6-1. Screen sequences

Each screen is classified by the screen frame as follows.

- Screens always displayed.
- Screens displayed or not displayed depending on some conditions.
- Screens displayed when any option is added.

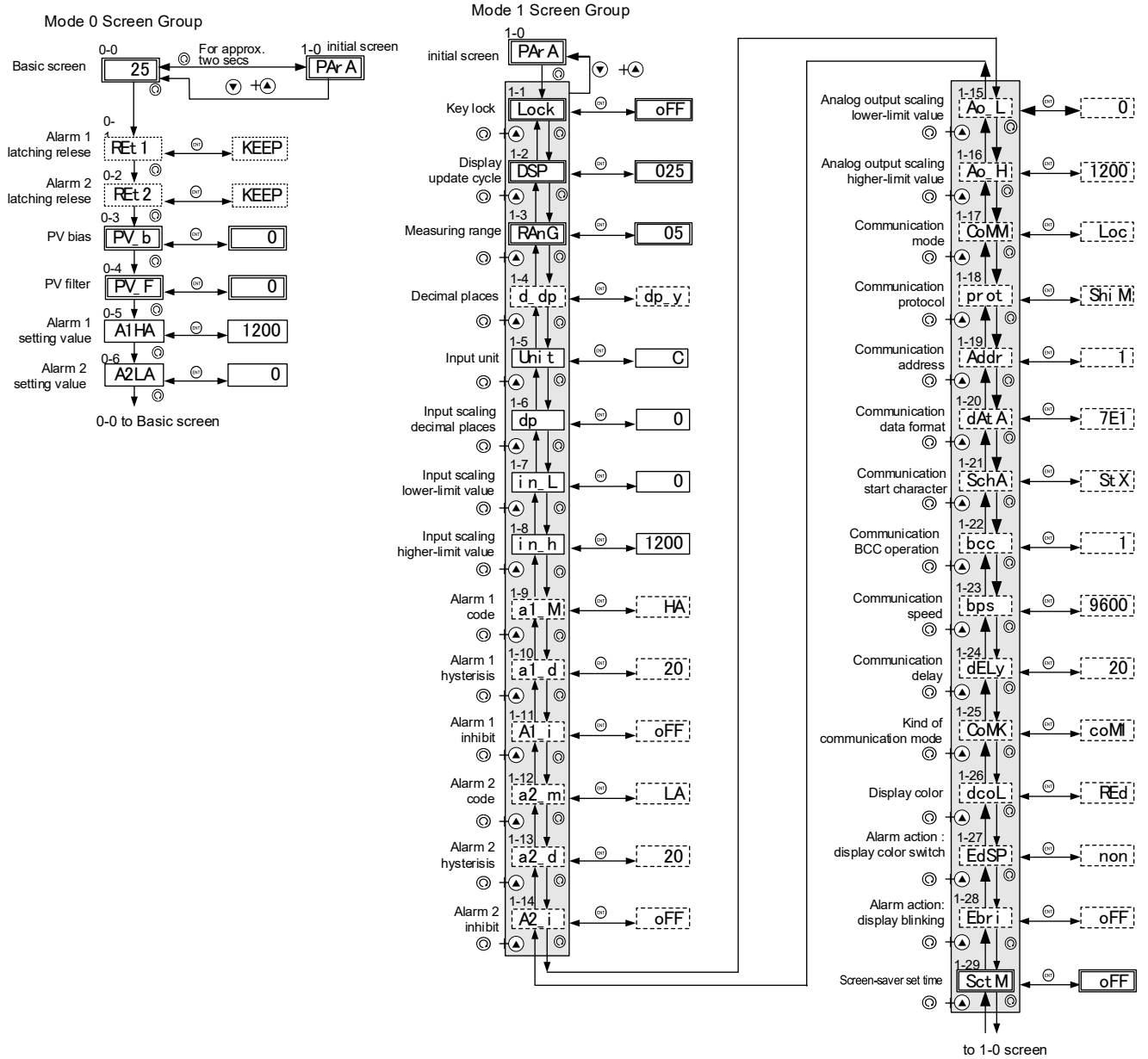







6-2. Power ON Screen Group

The following information is displayed automatically.





Model name	
Sd17	This device's internal version code (SD17) is displayed.
Input type	
tc	The input type is displayed. The type is either TC (thermocouple), Pt (R.T.D.), mV, V, or mA.
Measuring range, lower-limit value	
0	The lower-limit value of the input is displayed.
Measuring range, higher-limit value	
1200	The higher-limit value of input is displayed.
Note	No key operation is required as the screen changes automatically in the Power ON Screen Group.

6-3. Mode 0 Screen Group



The following informational icons are used from this sub-section.

	Setting/display is available when the alarm option is supported.		Setting/display is available when the analog output option is supported.
	Setting/display is available when the communication option is supported.		Setting/display is available when the display (11-segment red/white LEDs) option is supported.
	Setting/display is available when the voltage or current input is specified.		Setting/display is not available when the voltage or current input is specified.
R	Setting range	Ini	Initial value



Mode 0 Screen Group consists of screens that are often used under control operation. The commonly-used key operations are as follows:

- Shifting a display screen to the next display screen 
- Shifting a display screen to the setting screen 
- Returning from a setting screen to the display screen 
- Shifting from 0-0 screen to 1-0 screen  approx. 2 secs.



0-0 Basic screen

25	PV (measured value) is displayed.
Note	In case the Alarm 1 or 2 signal is output with the latching feature, use  key on this screen to release the Alarm 1 latching, or use  key on this screen to release the Alarm 2 latching.

0-1 Alarm 1 latching release

REt1	This screen is displayed when Alarm 1 is in the latching state, and is used for releasing it from that state. 
	This screen is displayed in case Alarm 1 code (1-9) is selected from the one with latching, and when the instrument is in the latching state. Set the parameter RSET to stop the alarm output. As for the latching feature, refer to "Latching feature" of "7. Alarm output." KEEP : Alarm output is ON with latching feature. RSET : Releasing the alarm with latching feature.
Note	The Alarm 1 output signal with latching feature can also be set to OFF by pressing  key on the Basic screen (0-0).
R	KEEP, RSET
Ini	KEE KEEP

0-2 Alarm 2 latching release

REt2	This screen is displayed when Alarm 2 is in the latching state, and is used for releasing it from that state. 
	This screen is displayed in case Alarm 2 code (1-12) is selected from the one with latching, and when the instrument is in the latching state. Set the parameter at RSET to stop the alarm output. As for the latching feature, refer to "Latching feature" of "7. Alarm output." KEEP : Alarm output is ON with latching feature. RSET : Releasing the alarm with latching feature.
Note	The Alarm 2 output signal with latching feature can also be set to OFF by pressing  key on the Basic screen (0-0).

R	KEEP, RSET	Ini	KEEP
----------	------------	------------	------

0-3 PV bias

PV_b	The PV bias value is displayed or can be set. The value is used for compensating input errors by the sensor, etc. When the value is set, the compensated PV is displayed.		
R	-1999 - 2000 digit	Ini	0 digit

0-4 PV filter

PV_F	The PV filter time is displayed or can be set. The value is helpful for reducing the adverse effect of noise from a PV input.		
Note	The PV filtering is temporarily disabled when the instrument is recovering from scale over.		
R	0 - 100 seconds	Ini	0

0-5 Alarm1 setting value

A1HA	Alarm 1 setting value is displayed or can be set.  One of the following Alarm 1 action types (1-9) is displayed on the screen. A1HA : Higher-limit absolute value A1LA : Lower-limit absolute value A1H.A. : Higher-limit absolute value (with latching) A1L.A. : Lower-limit absolute value (with latching)
-------------	------------------------------------------------------------------------------------------------------------------------------------------------------------------------------------------------------------------------------------------------------------------------------------------------------------------------------------------------------------------------------------------------------------------

Note	This screen is not displayed when non or So (scale over) is selected on Alarm 1 code screen (1-9).		
R	Measuring range lower-limit to higher-limit value	Ini	Higher-limit value

0-6 Alarm 2 setting value

A2LA	Alarm 2 setting value is displayed or can be set.  One of the following Alarm 2 action types (1-12) is displayed on the screen. A1HA : Higher-limit absolute value A1LA : Lower-limit absolute value A1H.A. : Higher-limit absolute value (with latching) A1L.A. : Lower-limit absolute value (with latching)
-------------	-------------------------------------------------------------------------------------------------------------------------------------------------------------------------------------------------------------------------------------------------------------------------------------------------------------------------------------------------------------------------------------------------------------------

Note	This screen is not displayed when non or So (scale over) is selected on Alarm 2 code screen (1-12).		
R	Measuring range lower-limit to higher-limit value	Ini	Lower-limit value

6-4. Mode 1 Screen Group

Mode 1 Screen Group consists of screens that are used less often than Mode 0 screens, and are required according to the input type or controllability. The commonly-used key operations are as follows:

- Shifting a display screen to the next display screen
- Returning from a display screen to the previous display screen +
- Shifting a display screen to the setting screen
- Returning from a setting screen to the display screen
- Returning from any display screen of Mode 1 to 1-0 screen +
- Returning from 1-0 screen to 0-0 screen approx. 2 secs
or +

Auto return feature

If no key operation is executed for 3 minutes or more other than the basic screen (screen 0-0), the screen automatically returns to the basic screen.

1-0 Mode 1 initial screen

PArA This is the heading screen of Mode 1 screens.

1-1 Key lock

Lock Key lock status is displayed or can be set. When the key lock is set to ON, parameter value modification is not allowed.

R OFF, ON **Ini** OFF

1-2 Display update cycle

DSP The display update cycle of PV is displayed or can be set.

R 0.25 - 5.00 secs. Set by 0.25 secs. **Ini** 0.25

1-3 Measuring range

RAnG The input type is displayed or can be set. Refer to "4. Measuring range code table" for input type details.

R 01 - 12, 31 - 34, 71, 81 - 83, 95 **Ini** 05 (K, TC 0 - 1200°C)

1-4 Decimal places

d_dp The decimal place with/without status is displayed or can be set.
dp_y : with decimal places
dp_n : without decimal places



Note In case the measuring range that doesn't support decimal places is specified, this screen is not displayed. Once this setting is modified from "with decimal places" to "without decimal places", the values of input scaling, analog output scaling, alarm setting, alarm hysteresis, and PV bias are rounded to the nearest integer. Then that setting is modified to "with decimal places" again, the value after the decimal places remains 0.

R dp_y, dp_n **Ini** dp_y

1-5 Input unit

Unit The input unit is displayed or can be set.



R °C, °F **Ini** °C

1-6 Input scaling decimal places

dp The scaling decimal places for voltage/current system input are displayed or can be set.



Note Other than voltage/current system input, display only.

R nnnn. - n.nnn **Ini** n.n

1-7 Input scaling lower-limit value

in_L The scaling lower-limit value for voltage/current input is displayed or can be set.



Note Other than voltage/current input, display only. The span between lower-limit and higher-limit is 10 - 10000. Reverse scaling is available.

R -1999 - 9999 digit **Ini** 0 digit

1-8 Input scaling higher-limit value

in_h The scaling higher-limit value for voltage/current input is displayed or can be set.



Note Other than voltage/current input, display only. The span between the lower-limit and the higher-limit is 10 - 10000. Reverse scaling is available.

R -1999 - 9999 digit **Ini** 1000 digit

1-9 Alarm 1 code

A1 M The Alarm 1 action type is displayed or can be set.



As for action types, refer to "Action type" of "7. Alarm output."

non : none
HA : Higher-limit absolute value
LA : Lower-limit absolute value
HA_L : Higher-limit absolute value (with latching)
LA_L : Lower-limit absolute value (with latching)
So : Scale over

Note Once the alarm code is changed, the preset values are initialized. However, they are not initialized when the code is changed HA<->HA_L, or LA<->LA_L.

R non, HA, LA, HA_L, LA_L, So **Ini** HA

1-10 Alarm 1 hysteresis

A1_d The Alarm 1 hysteresis is displayed or can be set.



Note This screen is not displayed when non or So (scale over) is selected on the Alarm 1 code screen (1-9).

R 1 - 999 digit **Ini** 20 digit

1-11 Alarm 1 inhibit

A1 i The Alarm 1 inhibit status is displayed or can be set.



Note This screen is not displayed when non or So (scale over) is selected on the Alarm 1 code screen (1-9).

R OFF, ON **Ini** OFF

1-12 Alarm 2 code

A2 m The Alarm 2 action type is displayed or can be set.



As for action types, refer to "Action type" of "7. Alarm output."

non : none
HA : Higher-limit absolute value
LA : Lower-limit absolute value
HA_L : Higher-limit absolute value (with latching)
LA_L : Lower-limit absolute value (with latching)
So : Scale over

Note Once the alarm code is changed, the preset values are initialized. However, they are not initialized when the code is changed HA<->HA_L, or LA<->LA_L.

R non, HA, LA, HA_L, LA_L, So **Ini** LA

1-13 Alarm 2 hysteresis

A2 d The Alarm 2 hysteresis is displayed or can be set.



Note This screen is not displayed when non or So (scale over) is selected on the Alarm 2 code screen (1-12).

R 1 - 999 digit **Ini** 20 digit

1-14 Alarm 2 inhibit

The Alarm 2 inhibit status is displayed or can be set. 

Note This screen is not displayed when non or So (scale over) is selected on the Alarm 2 code screen (1-12).

R OFF, ON  OFF

1-15 Analog output scaling lower-limit value

Ao I The analog output scaling lower-limit value is displayed or can be set. 

Note Reverse scaling is available.
The same value cannot be set for the lower-limit value and the higher-limit value (on screen 1-16).

R Measuring range lower-limit value to higher-limit value  Lower-limit value

1-16 Analog output scaling higher-limit value

Ao H The analog output scaling higher-limit value is displayed or can be set. 

Note Reverse scaling is available.
The same value cannot be set for the lower-limit value (on screen 1-15) and the higher-limit value.

R Measuring range lower-limit value to higher-limit value  Higher-limit value

1-17 Communication mode

Comm The communication mode is displayed or can be set. 

LOC : Local mode. Data can be read out via communication.
COM : Communication mode. Data can be set and read out via communication.

Note Once the communication mode is modified to COM via communication, the setting can no longer be made with front panel keys. However, the modification from COM to LOC is available.
For details, refer to the separated Communication Interface Instruction Manual.

R LOC, COM  LOC

1-18 Communication protocol

Prot The communication protocol is displayed or can be set. 

SHIM : Standard protocol
ASC : MODBUS ASCII
RTU : MODBUS RTU

R SHIM, ASC, RTU  SHIM

1-19 Communication address

Addr The communication address is displayed or can be set. 

Max. of 31 devices can be connected via RS-485, however the communication is executed with one to one. Communication address is used for discrimination of each instrument.

R 1 - 255  1

1-20 Communication data format

datA The communication data format is displayed or can be set. 

The setting value is composed of three alphanumerical characters.

Left character : Data length (bits). 7 or 8
Middle character : Parity. E (even) or N (none)
Right character : Stop bit. 1 or 2

Note For MODBUS ASCII, specify one of the 7-bit format types. The default value is 7E1.
For MODBUS RTU, specify one of the 8-bit format types. The default value is 8E1.

R 7E1, 7E2, 7N1, 7N2, 8E1, 8E2, 8N1, 8N2  7E1

1-21 Communication start character

SchA The start character of communication data is displayed or can be set. 

STX Start character STX (02H)
Text end ETX (03H)
End character CR (0DH)
ATT Start character @ (40H)
Text end : (3AH)
End character CR (0DH)

Note MODBUS ASCII/RTU doesn't use a start character.

R STX, ATT  STX

1-22 Communication BCC operation

bcc The BCC operation method is displayed or can be set. 

- 1 : ADD operation from the start character to the text-end character
- 2 : 2's complement after ADD operation from the start character to the text-end character.
- 3 : XOR operation from after the start character to the text-end character.
- 4 : BCC operation is not performed.

Note MODBUS ASCII/RTU doesn't use BCC.

R 1 - 4  1

1-23 Communication speed

bps The communication speed is displayed or can be set. 

Note In case of 19200 bps, "1920" is displayed on the screen.

R 1200, 2400, 4800, 9600, 19200, 38400 bps  9600

1-24 Communication delay

dELy The delay time by communication, between time of receiving a command and sending the reply, is displayed or can be set. 

Delay time (msec) = setting value (digit) x 1.0 (msec)

Note In case of RS-485, some line converters expend a longer time to perform 3-state control, and signal collisions may occur. This can be avoided to set it longer delay time.

Actual delay time from the reception of a communication command to transmission is a total of the above-described delay time and the time for software to process the command. Processing the Write command, in particular, may take about 400 msec in some case.

R 1 - 100 msec  20

1-25 Communication mode type

CoMk Communication mode type is displayed or can be set. 

If you want to perform key operation during the write process via communication, set to COM1.

Communication mode type	COM1		COM2	
Communication mode	COM	LOC	COM	LOC
Key operation	possible	possible	impossible	possible
writing	possible	possible	possible	impossible

When rewriting communication mode type with communication command, it'll be as follows:

Communication mode	LOC	COM
writing	COM1 → COM2 possible	COM1 → COM2 possible
	COM2 → COM1 impossible	COM2 → COM1 possible

R COM1, COM2  COM1

1-26 Display color

dcol The color of display can switch red and white.
 RED : red
 WHIT : white

R RED, WHIT **Ini** RED

1-27 Alarm action :display color switch

EdSP The color of display can switch by alarm action. **BI**
 NON: color not switch
 CHG: color switch

R NON, CHG **Ini** NON

1-28 Alarm action: display blinking

Ebri The display can blink by alarm action. **AL**
 OFF : display not blinking
 ON : display blinking

R OFF, ON **Ini** OFF

1-29 Screen-saver set time

SctM When there is no key operation beyond set time, the display turns off.

Note The time unit is minutes.

R OFF, 1 to 100 minutes **Ini** OFF

7. Alarm output

The instrument supports two points of alarm optionally.

Action type

The following alarm output action types (screen 1-9 or 1-12) are supported.

The lower-limit absolute value alarm

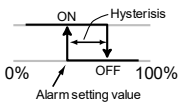

The higher-limit absolute value alarm

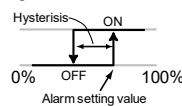

Scale over

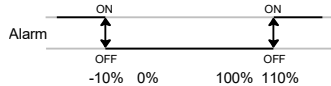

Inhibit action

When the alarm output inhibit action is set to ON (on screen 1-11 or 1-14), the inhibit action at power on is performed, as follows.

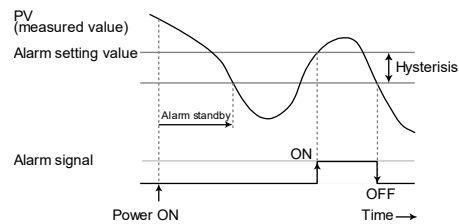

Latching feature

The latching feature outputs the alarm signal constantly once PV is detected in the alarm action region, even if PV is out of the alarm action region later.

Note When PV is in the alarm action region, latching cannot be released. To release the latching, refer to the description of screen 0-0, 0-1, or 0-2.

The latching feature is disabled.

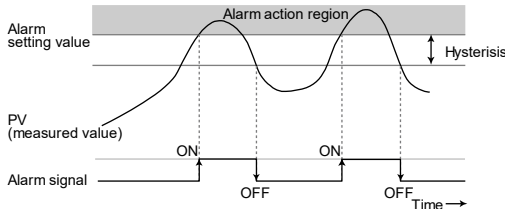

The latching feature is enabled.

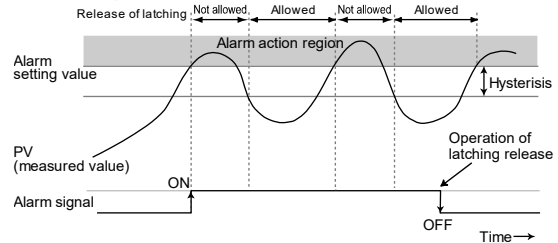

8. Analog output

Analog output is a feature that outputs PV value-based analog voltage or analog current. By setting the analog output scaling lower-limit value (screen 1-15) or higher-limit value (1-16), the analog output signal can be gained by PV value-base within a specified measuring range.

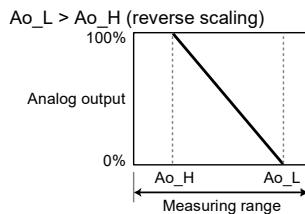
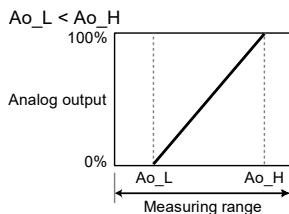

9. Sensor power supply

In case the optional DC sensor power supply (24V DC 25mA) is selected, the instrument can be used with the Humidity Sensor H71A/TH71A series. Note that if 08 of power (24V AC/DC) from type code is selected, the sensor power supply cannot be specified.

Wiring example using with Humidity Sensor H71A/TH71A

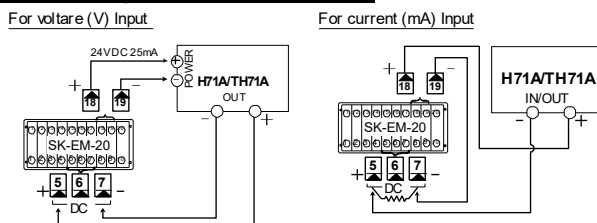

10. Communication

The instrument supports one of the two communication interfaces, RS-232C and RS-485. These allow you to set or get various data of the instrument from/into a personal computer or the like.

RS-232C and RS-485 are data communication standards established by the Electronic Industries Association of the U.S. (EIA). The standards cover electrical and mechanical aspects, that is, matters related to applicable hardware but not the data transmission procedure of software. Therefore, users need to have sufficient knowledge of specifications and transmission procedure.

10-1. Specification

Communication type	EIA RS-232C, RS-485 compatible	
Communication system	RS-232C, 3-line half duplex system RS-485, 2-line half duplex multi-drop (bus) system	
Synchronization system	Half duplex start-stop synchronization system	
Communication distance	RS-232C 15 m maximum RS-485 maximum total of 500 m (differs depending on conditions.)	
Communication speed	1200, 2400, 4800, 9600, 19200, 38400 bps	
Transmission procedure	No procedure	
Communication address	1 - 255	
Number of connectable devices	31 devices max. (for RS-485)	
Delay	1 - 100 msec	
Communication protocol	Standard protocol, MODBUS ASCII, MODBUS RTU	
Communication mode type	COM1 or COM2	
Standard	Data format	7E1, 7E2, 7N1, 7N2, 8E1, 8E2, 8N1, 8N2
	Control code	STX, ETX, CR, @, ., CR
	Checksum (BCC)	1 ADD operation from start character to text end character 2 2's complement after ADD operation from start character to text end character. 3 XOR operation from after start character to text end character. 4 BCC operation is not performed.
	Communication code	ASCII Code
MODBUS ASCII	Data format	7E1, 7E2, 7N1, 7N2
	Control code	CRLF
	Error check	LRC check
	Communication code	ASCII Code
MODBUS RTU	Data format	8E1, 8E2, 8N1, 8N2
	Control code	None
	Error check	CRC check
	Communication code	Binary code
Isolation	Isolated between communication and input, between communication and alarm output, between communication and analog output (sensor power supply), or between communication and system.	

10-2. Connecting with host computer

(1) RS-232C

This indicator is provided with only 3 lines for input and output, i.e., for data transmission, data reception and grounding for signals, not with any other signal lines. Since the indicator has no control line, control signals should be handled on the host side. The following drawing shows an example of control signal processing methods. As the method depends on the system, however, please use this instrument with regard to the host computer's specifications.

Connection Example

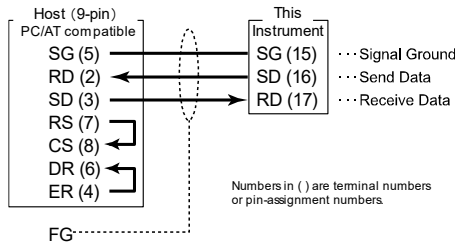

(2) RS-485

Multiple indicators can be connected by introducing RS-485. In case of connecting via RS-485 on personal computers, please attach off-the-shelf "RS-485 converter."

When the RS-485 communication system is employed, the last indicator needs to be attached with a terminal resistor. The attached terminal resistor (1/2W 120Ω or so) should be inserted across the terminals (16) and (17).

The transmission output is held at high impedance until just before starting of sending data. For more details, refer to "Control of 3-state output."

Connection Example

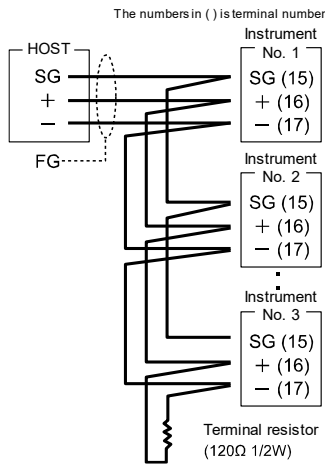

(3) Control of 3-state output

As the collision of sending signals should be avoided, in case of RS-485, transmission output is held at high impedance while communication is not carried out and during reception. Output is switched from high impedance to its ordinary state immediately before the start of sending data and is controlled to high impedance again when the communication ends. Note that the 3-state control delays by about 1msec (max) after the transmission of the end bit of the end characters. Therefore, a delay time of a few milliseconds or longer should be provided in case the host starts transmission upon termination of reception.

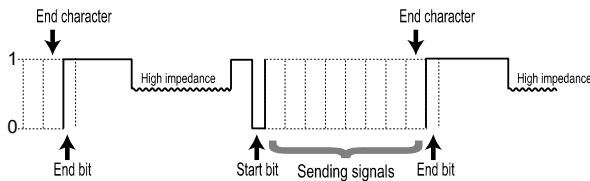

10-3. Standard protocol

The following is description about standard protocol.

(1) Communication overview

Communication is performed per a data block. Personal computers or PLC (host) always roles a "master", and SK-EM-20 always roles a "slave", that is, the host starts a communication by sending a communication command and the slave terminates the communication by replying the command. Note, however, that there is no reply from the slave when data format error has occurred or when it is the broadcast command.

Note

When this instrument receives a start character and doesn't receive the end character in about one second, this command is processed as timeout, and the instruments shifting to the waiting state for the next command (start character). For this, if timeout is set on host, set it for more than one second.
This instrument doesn't support the broadcast command.

(2) Recommended communication format

The following parameter setting combination is recommended for convenience or avoiding confuse on settings, although this instrument supports various communication/data formats.

Data format	7E1 (Data length:7, parity: E, stop bit: 1)
Control code	STX (STX_ETX_CR)
Checksum (BCC)	1 (ADD operation)

(3) Overview of protocol format

Standard protocol is composed of "Basic format section I", "Text section", and "Basic format section II." The protocol format send from host and the one respond from slave are common. Note that the format of Text section and BCC operation result is different.

(4) Basic format section

The following is description about the Basic format section I and II.

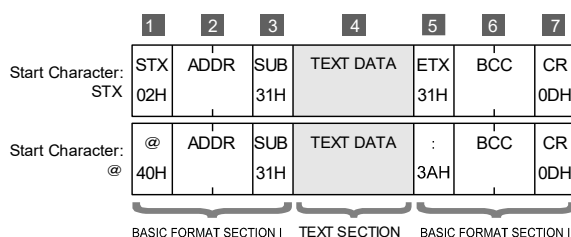

1	Start character Indicates that the start of a data block. STX (02H) or @ (40H)																														
2	Communication address of the slave (destination address) The communication address of 1 to 255 (0000 0001 - 255: 1110 1111) are separated into high-order 4 bits and low-order 4 bits and converted to ASCII data. Ex: If the address is "100 (64H)", the high-order is "36H" and the low-order is "34H."																														
3	Sub address This is fixed to "1 (31H)."																														
4	Text data The data which is actually received/sent. Please refer to "(5) Text section" for details.																														
5	Text end characters Indicates that the end of communication block. "ETX (03H)" or ":" (34H)."																														
6	BCC operation result Please refer to "(5) Text section" for details about 4 (Text section) in the following illustration. 1. ADD operation ADD operation from start character (1) to text end character (5) in unit of byte (one ASCII character). Ex.: <table border="1"> <tr> <td>1</td> <td>2</td> <td>3</td> <td>4</td> <td>5</td> </tr> <tr> <td>STX</td> <td>ADDR</td> <td>SUB</td> <td>R/W</td> <td>FIRST ADDRESS</td> </tr> <tr> <td>STX</td> <td>01</td> <td>1</td> <td>R</td> <td>0 1 0 0</td> </tr> </table> $02H + 30H + 31H + 31H + 52H + 30H + 31H + 30H + 30H + 39H + 03H = 1E3H$ <p>In this example, the ASCII converted string from E or 3, the lower 1 byte value of 1E3H, will be stored in the higher/the lower field of BCC respectively.</p> 2. 2's complement after ADD operation ADD operation from start character (1) to text end character (5) in unit of byte (one ASCII character), and 2's complement to the result of lower one byte will be stored. Ex.: <table border="1"> <tr> <td>1</td> <td>2</td> <td>3</td> <td>4</td> <td>5</td> </tr> <tr> <td>STX</td> <td>ADDR</td> <td>SUB</td> <td>R/W</td> <td>FIRST ADDRESS</td> </tr> <tr> <td>STX</td> <td>01</td> <td>1</td> <td>R</td> <td>0 1 0 0</td> </tr> </table> $02H + 30H + 31H + 31H + 52H + 30H + 31H + 30H + 30H + 39H + 03H = 1E3H$ <p>In this example, 2's complement of E3H, the lower 1 byte data of 1E3H, will be 1DH, and the ASCII converted string from 1 or D will be stored in the higher/the lower field of BCC respectively.</p>	1	2	3	4	5	STX	ADDR	SUB	R/W	FIRST ADDRESS	STX	01	1	R	0 1 0 0	1	2	3	4	5	STX	ADDR	SUB	R/W	FIRST ADDRESS	STX	01	1	R	0 1 0 0
1	2	3	4	5																											
STX	ADDR	SUB	R/W	FIRST ADDRESS																											
STX	01	1	R	0 1 0 0																											
1	2	3	4	5																											
STX	ADDR	SUB	R/W	FIRST ADDRESS																											
STX	01	1	R	0 1 0 0																											

	<p>3. Exclusive OR operation XOR operation from after the start character (2) to text end character (5) in unit of byte (one ASCII character). Ex.:</p> <div style="text-align: center;"> <table border="1" style="margin: auto;"> <tr> <td style="border: none;">1</td> <td style="border: none;">2</td> <td style="border: none;">3</td> <td colspan="2" style="border: none;">4</td> <td style="border: none;">5</td> </tr> <tr> <td>@</td> <td>ADDR</td> <td>SUB R/W</td> <td colspan="2">FIRST ADDRESS</td> <td>DC :</td> </tr> <tr> <td>@</td> <td>01</td> <td>1 R</td> <td colspan="2">0100</td> <td>9 :</td> </tr> </table> <p style="font-size: small; margin-top: 5px;"> $30H \wedge 31H \wedge 31H \wedge 52H \wedge 30H \wedge 31H \wedge 30H \wedge 30H \wedge 39H \wedge 3AH = 60H$ ^ indicates exclusive OR </p> </div> <p>In this example, the ASCII converted string from 6 or 0, the lower 1 byte value of 60H which is the result from XOR, will be stored in the higher/the lower field of BCC respectively.</p>	1	2	3	4		5	@	ADDR	SUB R/W	FIRST ADDRESS		DC :	@	01	1 R	0100		9 :
1	2	3	4		5														
@	ADDR	SUB R/W	FIRST ADDRESS		DC :														
@	01	1 R	0100		9 :														
	<p>4. No BCC operation BCC operation is not executed. The data doesn't have BCC field (6).</p>																		
7	<p>End characters The end of the communication block. CR (0DH)</p>																		

(5) Text section

The following is description about the Text section. This is the 4 part described above. The Text section format differs between the data from the master and the data from the slave.

Command data format (from master)

The data format sent from the master (a host) is described below.

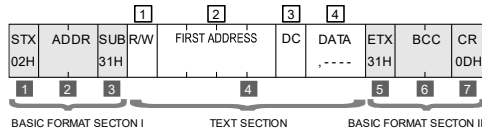

Reply data format (from slave)

The data format sent from the slave is described below.

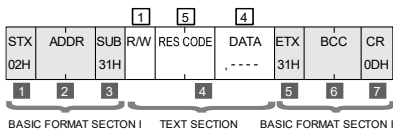

1	<p>Command 'R' (52H) or 'W' (57H) 'R' (Read): Readout data from slave (Host retrieves data from slave). 'W' (Write): Write data to slave (Host sends data to slave).</p>																		
2	<p>The first address of the data The first address of the data to be read/written from/to. Please refer to "10-5. Communication data address list" for the list of addresses. Ex.:</p> <div style="text-align: center;"> <table border="1" style="margin: auto;"> <tr> <td style="border: none;">2</td> <td style="border: none;">FIRST ADDRESS</td> </tr> <tr> <td style="border: none;">30H, 37H, 30H, 31H</td> <td style="border: none;">0 7 0 1</td> </tr> </table> <p style="font-size: small; margin-top: 5px;">ASCII conversion</p> </div> <p>This example indicates the PV bias address.</p>	2	FIRST ADDRESS	30H, 37H, 30H, 31H	0 7 0 1														
2	FIRST ADDRESS																		
30H, 37H, 30H, 31H	0 7 0 1																		
3	<p>The number of data The data counts for reading/writing. If multiple sequential data is processed, this range can be specified by this number. The valid value is 0 to 9 (1 to 10 data) for 'R' (Read), and 0 (1 data) for 'W' (Write), note that the actual number of data will be one-incremented value to the specified value. Ex.:</p> <div style="text-align: center;"> <table border="1" style="margin: auto;"> <tr> <td style="border: none;">3</td> <td style="border: none;">DC</td> </tr> <tr> <td style="border: none;">32H</td> <td style="border: none;">2</td> </tr> </table> <p style="font-size: small; margin-top: 5px;">ASCII conversion</p> </div> <p>This example indicates that it specifies three data starting from the address specified in 2.</p>	3	DC	32H	2														
3	DC																		
32H	2																		
4	<p>Data The data which is actually received/sent. The data specified in the 3 field are sent as one data block. The block starts from "," (2CH), and this indicates that the block is actual data. Delimiters (special characters inserted between data to indicate start/end of data) are not inserted. Ex.:</p> <div style="text-align: center;"> <table border="1" style="margin: auto;"> <tr> <td style="border: none;">4</td> <td style="border: none;">HEAD</td> <td style="border: none;">The first data</td> <td style="border: none;">The second data</td> <td style="border: none;">..</td> <td style="border: none;">The Nth data</td> </tr> <tr> <td style="border: none;">2CH</td> <td style="border: none;">30H, 31H, 30H, 30H</td> <td style="border: none;">30H, 30H, 31H, 30H</td> <td style="border: none;">..</td> <td style="border: none;">..</td> <td style="border: none;">..</td> </tr> <tr> <td style="border: none;">,</td> <td style="border: none;">0 1 0 0 0 0 1 0</td> <td colspan="4"></td> </tr> </table> <p style="font-size: small; margin-top: 5px;">ASCII conversion</p> </div> <p>This example shows that the actual receive/sending data block contains "100H" in the first data field, "10H" in the second data field, until the data in the "N" th field.</p>	4	HEAD	The first data	The second data	..	The Nth data	2CH	30H, 31H, 30H, 30H	30H, 30H, 31H, 30H	,	0 1 0 0 0 0 1 0				
4	HEAD	The first data	The second data	..	The Nth data														
2CH	30H, 31H, 30H, 30H	30H, 30H, 31H, 30H														
,	0 1 0 0 0 0 1 0																		
5	<p>Response code The response code from the slave. Ex.:</p> <div style="text-align: center;"> <table border="1" style="margin: auto;"> <tr> <td style="border: none;">5</td> <td style="border: none;">RES CODE</td> </tr> <tr> <td style="border: none;">30H, 30H</td> <td style="border: none;">0 0</td> </tr> </table> <p style="font-size: small; margin-top: 5px;">ASCII conversion</p> </div> <p>Please refer to "5-8. Response codes" for details.</p>	5	RES CODE	30H, 30H	0 0														
5	RES CODE																		
30H, 30H	0 0																		

(6) Read command

The Read command 'R' is used by a master to read (take) various data in slave.

Command data format (from master)

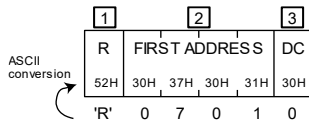

- 1 'R' (52H) indicates that this is the Read command.
- 2 The start data address of data to be read.
- 3 The number of data (words) to be read counting from the start data address. Valid value is 0 to 9. If multiple sequential data is read, the range can be specified by the number. The actual numbers of data is one incremented value specified to this field.

Reply data format (from slave)

When the communication ends successfully	When the communication ends abnormally
<ol style="list-style-type: none"> 1 'R' (52H) indicates that this is the Read command. 5 Response code 00 (30H 30H) is returned when no error. 4 The data actually read. ',' (2CH, comma) is always added to the head of data. One more data specified in the 3 field of command format from master will be actually read. 	<ol style="list-style-type: none"> 1 'R' (52H) indicates that this is the Read command. 5 Response code A code number is inserted to represent the situation. Please refer to "(8) Response codes" for details.

(7) Write command

The Write command 'W' is used by a master to write (input) various data to a slave.

Note

To use the Write command, the communication mode parameter should be set on COM. Note, however, the communication mode can be shifted from LOC to COM only with communication feature. Shift from LOC to COM by sending the following command.

STX	ADDR	SUB	W	FIRST ADDRESS	DC	DATA	ETX	BCC	CR
02H	30H 31H	31H	57H	30H 31H 38H 43H	30H	52H 30H 30H 30H 31H	03H	30H 33H	0DH
1	2	3	4	4	5	6	7		

- 1 Start character. In this example, STX (02H) is used. In case using '@', this value is 40H.
- 2 Communication address. In this example, 01 (30H 31H) is used.
- 3 Sub address. 01 (31H) is fixed for this instrument.
- 4
 - 1 'W' (The Write command)
 - 2 018C (30H 31H 38H 43H), the data address indicating communication mode.
 - 3 The number of data. Specify 0 (30H) here because there is only one data to be written.
 - 4 The data to be written. The data will be a comma (, (2CH) which indicates the head of data, and 0001 (30H 30H 30H 31H) which indicates COM.
- 5 Text end characters. Specify ETX (03H) in case STX is specified in 1. Specify ':' (3AH) in case '@' is specified in 1.
- 6 Result of BCC operation.
- 7 End characters. CR (0DH) is fixed for this instrument.

Command data format (from master)

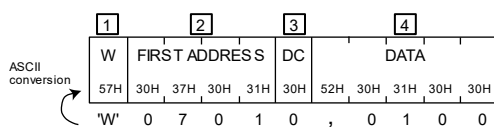

- 1 'W' (57H) indicates that this is the Write command.
- 2 The first address of writing data.
- 3 The number of data to be written. The value is always 0 (the number of data which is able to be written is always one).
- 4 The data actually written. ',' (2CH, comma) is always added to the head of data. The number of data to be written is only 1.

Reply data format (from slave)

When the communication ends successfully	When the communication ends abnormally
<ol style="list-style-type: none"> 1 'W' (57H) indicates that this is the Write command. 5 Response code 00 (30H 30H) is returned when no error. 	<ol style="list-style-type: none"> 1 'W' (57H) indicates that this is the Write command. 5 Response code A code number is inserted to represent the situation. Please refer to "(8) Response codes" for details.

(8) Response codes

The following lists response codes of the standard protocol. Other than 00H (30H 30H) are error codes.

Response code	Condition	Descriptions
00H (30H 30H)	Communication ends successfully	The response code to a command indicating that the communication ends normally.
07H (30H 37H)	Format error	The data format of Text section differs from the defined one.
08H (30H 38H)	Error in address or number of data	The data address or the number of data differs from the defined one.
09H (30H 39H)	Data error	The address of data to be written is out of its setting range.
0AH (30H 41H)	Execution command error	The execution command cannot be accepted.
0BH (30H 42H)	Write mode error	Write command is issued with any data which is invalid to be written.
0CH (30H 43H)	Option error	Read/Write command is issued with option relating data although the option is not added.

Note The smaller value of response code, the higher the priority. In case multiple errors have occurred, only the smallest value of response code is returned.

(9) No response condition

If a slave found one of the errors listed below when the slave received a data block from a host, slave doesn't send response data, and waits for the next data from host instead.

- Hardware interface error has occurred (flaming, overrun, parity).
- Mismatch of communication address.
- Start character violation (other than STX or @ is specified).
- Sub address violation (other than 1 (31H) is specified).
- Other than 'R' or 'W' is specified in a command field.
- Text end character violation (other than ETX or : is specified).
- BCC operation result is different.
- End character violation (other than CR (0DH) is specified).

10-4. MODBUS protocol

The following is a description about MODBUS protocol.

(1) Communication overview

MODBUS protocol is a communication protocol for PLCs which is developed by Modicon Inc. (AEG Schneider Automation International S.A.S).

MODBUS protocol has ASCII mode and RTU mode. Under ASCII mode, 8-bit binary data is divided into two, 4-bit and 4-bit, and each 4-bit data is transmitted after ASCII conversion. Under RTU mode, 8-bit binary data is transmitted without ASCII conversion. Devices which belong to the network should be selected the same mode.

In case of MODBUS protocol, a host is the master and SK-EM-20 is a slave, the host always starts a communication, and the communication terminates by the reply from the slave.

(2) Message format

MODBUS ASCII mode

The following is a message format of MODBUS ASCII mode.



1	<p>Header Indicates that the head of the message. : (3AH), fixed</p>																		
2	<p>Communication address of slave (destination address) The communication address value are separated into high-order 4-bit and low-order 4-bit and converted to ASCII data. For example, if the address is "100 (64H)", the high-order is "36H" and the low-order is "34H." The communication address setting range is 1 to 255 for this instrument.</p>																		
3	<p>Function code A command to slaves. Please refer to "(5) Function codes" for details.</p>																		
4	<p>Data The data which is actually received/sent.</p>																		
5	<p>LRC check LResult of LRC check (longitudinal redundancy check). Check by the result of 2's complement after ADD operation. 2's complement after ADD operation The message filed from communication address (2) to data (4) is converted into binary data (1-byte) by ASCII data 2-character (2-byte) unit, ADD each binary data, and take 2's complement of the lowest 1-byte. Ex.:</p> <table border="1" style="margin-left: 20px;"> <tr> <td style="text-align: center;">1</td> <td style="text-align: center;">2</td> <td style="text-align: center;">3</td> <td style="text-align: center;">4</td> <td style="text-align: center;">5</td> <td style="text-align: center;">6</td> </tr> <tr> <td style="text-align: center;">:</td> <td style="text-align: center;">ADDR</td> <td style="text-align: center;">FUNC</td> <td style="text-align: center;">DATA</td> <td style="text-align: center;">LRC</td> <td style="text-align: center;">CR LF</td> </tr> <tr> <td style="text-align: center;">3AH</td> <td style="text-align: center;">0 1</td> <td style="text-align: center;">0 3</td> <td style="text-align: center;">0 1 0 0 0 0 1</td> <td></td> <td style="text-align: center;">0DH 0AH</td> </tr> </table> <p style="margin-left: 20px; font-size: small;"> $01H + 03H + 01H+00H+00H+01H = 06H$ </p> <p>In this example, 2's complement of 0006H, the lower one byte data of 06H, will be FAH, and the ASCII converted string from F or A will be stored in the higher/the lower field of LRC respectively.</p>	1	2	3	4	5	6	:	ADDR	FUNC	DATA	LRC	CR LF	3AH	0 1	0 3	0 1 0 0 0 0 1		0DH 0AH
1	2	3	4	5	6														
:	ADDR	FUNC	DATA	LRC	CR LF														
3AH	0 1	0 3	0 1 0 0 0 0 1		0DH 0AH														
6	<p>Trailer Indicates the end of the message. CR (0DH) and LF (0AH), fixed.</p>																		

MODBUS RTU mode

The following is a message format of MODBUS RTU mode.



1	<p>Communication address of slave (destination address) Set the communication address. For example, if the address is "100 (64H)", the valid value is "64H." The communication address setting range is 1 to 255 for this instrument.</p>												
2	<p>Function code A command to slaves. Please refer to "(5) Function codes" for details.</p>												
3	<p>Data The data which is actually received/sent.</p>												
4	<p>CRC check Result of CRC check (cyclic redundancy check). CRC-16 algorithm Ex.:</p> <table border="1" style="margin-left: 20px;"> <tr> <td>1</td> <td>2</td> <td>3</td> <td>4</td> </tr> <tr> <td>ADDR</td> <td>FUNC</td> <td>DATA</td> <td>CRC</td> </tr> <tr> <td>01</td> <td>03</td> <td>0 1 0 0 0 0 0 1</td> <td></td> </tr> </table> <p>Explanatory, the following "CR" indicates a temporary value of CRC data (2-byte) for computation.</p> <ol style="list-style-type: none"> 1. Initialize "CR" (FFFFH). 2. Perform XOR operation between "CR" and 1, and assign the result to "CR." 3. Check the LSB (least significant bit) value. If it is 0, shift "CR" value 1-bit right. If it is 1, perform XOR operation between the right shift 1-bit of "CR" value and A001H, and assign the result to "CR." 4. Repeat the Step 3 seven times. 5. After repeating the Step 3 eight times, perform XOR operation between the current "CR" and the value of the next field (2), and assign the result to "CR." 6. After repeating the Step 5 eight times, perform XOR operation using the value of the next field, until just before CRC field (the last field of 3). 7. Switch the upper 8-bit and the lower 8-bit of the finally gained "CR", and assign the result to CRC field. 	1	2	3	4	ADDR	FUNC	DATA	CRC	01	03	0 1 0 0 0 0 0 1	
1	2	3	4										
ADDR	FUNC	DATA	CRC										
01	03	0 1 0 0 0 0 0 1											
Note	<p>In case MODBUS RTU, there is no field that indicates the start of a message. Instead, if a silent time of 3.5 characters or more is detected after receiving the last data of a message, the host's communication state transits to the data waiting state. Then, a message is sent, the host start to receive it. After that, when a silent time of 3.5 character or more is detected, the host terminates receiving the data and waits for a next message.</p>												

(3) Commands of MODBUS ASCII mode

Under MODBUS ASCII mode, the Read command, the Write command and the Loop back command are offered.

Read command

The Read command is used by a master to read (take) various data in slave.

Command data format (from master)

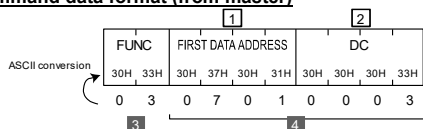

- 3 Function code. '03H' (30H 33H) indicates that this is a Read command.
- 4
 - 1 The start data address of data to be read.
 - 2 The number of data (words) to be read. The value of 1H to AH (ten, max.) can be assigned. If multiple sequential data is read, it can be specified by range.

Reply data format (from slave)

When the communication ends successfully

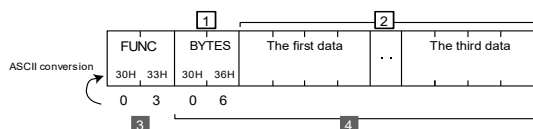

- 3 Function code. '03H' (30H 33H) indicates that this is the Read command.
- 4
 - 1 The byte of data (words) to be read.
 - 2 The data which is actually read.

When the communication ends abnormally

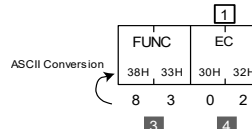

- 3 Function code '83' (38H 33H) indicates that this is an error message to the Read command.
- 4
 - 1 Error code
Please refer to "Error codes" in (5) for details.

Write command

The Write command is used by a master to write (input) various data to a slave.

It's necessary to change the communication mode to LOC-> COM at the time of light command use. But, it isn't possible to change this communication mode by a front key. Therefore please send the command from the master side, change it to COM from LOC and put it into effect.

- When the communication mode kind is COM2, you need movement above-mentioned.
- When the communication mode kind is COM1, it's unnecessary.

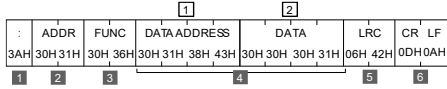

Note

- 1 Start character. : (3AH)
- 2 Communication address. In this example, 01 (30H 31H) is used.
- 3 Function code. 06 (30H 36H)
- 4 1 018C (30H 31H 38H 43H), the data address indicating communication mode.
2 The data to be written. 0001 (30H 30H 30H 31H) to specify the mode COM.
- 5 Result of LRC operation.
- 6 Trailer. CRLF (0DH 0AH)

Command data format (from master)

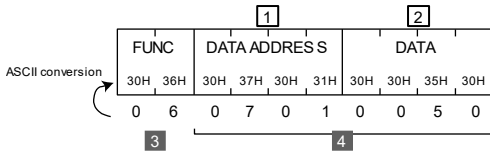

- 3 Function code. '06H' (30H 36H) indicates that this is the Write command.
- 4 1 The data address to be written.
2 The data to be written.

Reply data format (from slave)

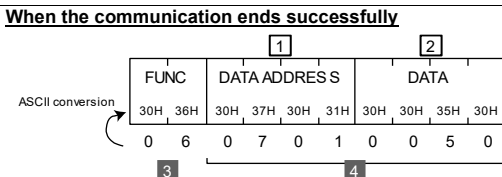

- 3 Function code. '06H' (30H 36H) indicates that this is the Write command.
- 4 1 The data address to be written.
2 The data to be written.

When the communication ends abnormally

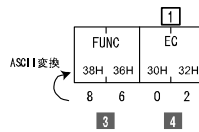

- 3 Function code '86' (38H 36H) indicates that this is the error message to the Read command.
- 4 1 Error code
Please refer to "Error codes" in (5) for details.

Loop back command

The Loop back command is sent from a master to a slave, and replied from the slave. This is used for status check if the destination instrument (slave) is alive.

Command data format (from master)

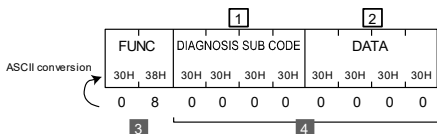

- 3 Function code. '08H' (30H 38H) indicates that this is a loop back command.
- 4 1 0000H (30H 30H 30H 30H) indicating this is a diagnosis sub code, fixed.
2 Data. This instrument ignores this field.

Reply data format (from slave)

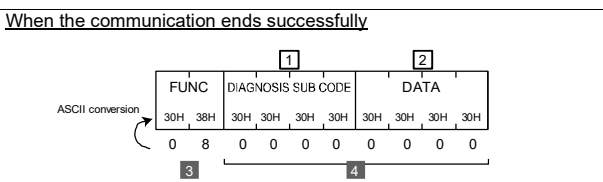

- 3 Function code. '08H' (30H 38H) indicates that this is a loop back command.
- 4 1 0000H (30H 30H 30H 30H) indicating this is a diagnosis sub code, fixed.
2 Data. This instrument ignores this field.

When the communication ends abnormally

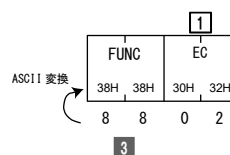

- 3 Function code '88H' (38H 38H) indicates that the communication has occurred an error to a loop back command.
- 4 1 Error code
Please refer to "Error codes" in (5), for details.

(4) Commands of MODBUS RTU mode

Under MODBUS RTU mode, the Read command, the Write command and the Loop back command are offered.

Read command

The following is a description about the Read command. The Read command is used by a master to read (take) various data in slave.

Command data format (from master)

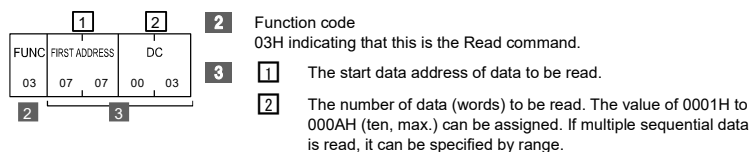

Reply data format (from slave)

When the communication ends successfully

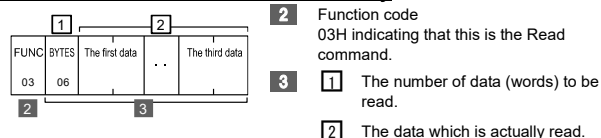

When the communication ends abnormally

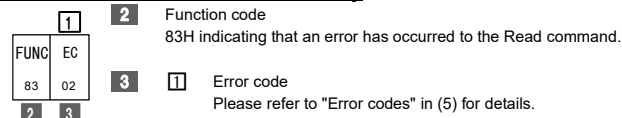

Write command

The following is a description about the Write command. The Write command is used by a master to write (input) various data to a slave.

注記

It's necessary to change the communication mode to LOC-> COM at the time of light command use. But, it isn't possible to change this communication mode by a front key. Therefore please send the command from the master side, change it to COM from LOC and put it into effect.

- When the communication mode kind is COM2, you need movement above-mentioned.
- When the communication mode kind is COM1, it's unnecessary.

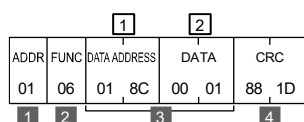

- 1: Communication address. In this example, 01 is used.
- 2: Function code. 06
- 3: 1: 018C, the data address indicating communication mode.
2: The data to be written. 0001 to specify the mode COM.
- 4: Result of CRC check.

Command data format (from master)

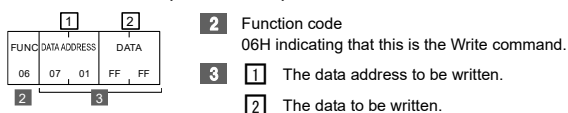

Reply data format (from slave)

When the communication ends successfully

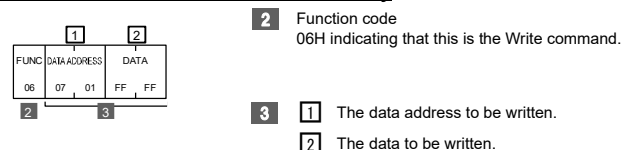

When the communication ends abnormally

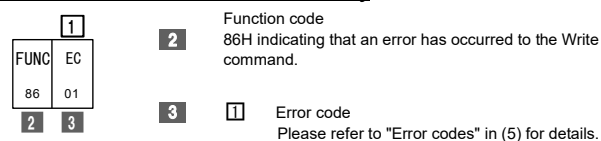

Loop back command

The following is a description about The Loop back command. The Loop back command is sent from a master to a slave, and replied from the slave. This is used for status check if the destination instrument (slave) is alive.

Command data format (from master)

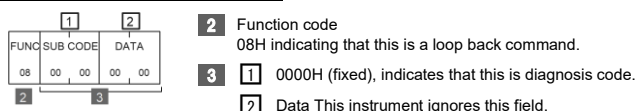

Reply data format (from slave)

When the communication ends successfully

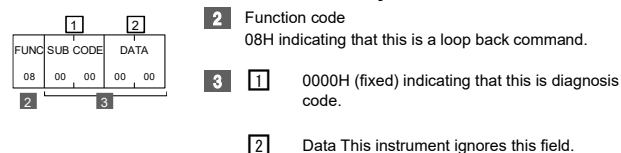

When the communication ends abnormally

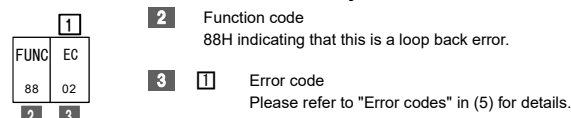

(5) Function codes

A function code indicates the command type for a slave. The same function code of the master is returned from a slave in case that the process terminates successfully. If the process is abnormally terminated, the MSB (Most Significant Bit) to the original function code is set to 1, and this revised function code is returned. The "Error codes" is also included in data field and returned.

Function codes

The instrument supports the following function codes.

Function codes	Descriptions
03 (03H)	The Read command. Read setting values or information in a slave.
06 (06H)	The Write command. Write values to a slave.
08 (08H)	The Loop back command. Indicates to reply the sending data as it is. This is used for status check if the destination instrument (slave) is alive.

Error codes

The instrument supports the following error codes.

Error codes	Descriptions
1 (01H)	An error relating features (ex. unsupported features).
2 (02H)	An error relating data address or data counts (The data address or data counts violation).
3 (03H)	Data error (The data is out of its valid range).

(6) No response condition

If a slave found one of the errors listed below when it received a data block from a host, it doesn't send response data, and waits for the next data from host instead.

MODBUS ASCII mode	MODBUS RTU mode
<ul style="list-style-type: none"> Hardware interface error has occurred (flaming, overrun, parity). Mismatch of communication address. Header is wrong (specified other than :). Function code is other than 03H, 06H, or 08H. LRC operation result is different. The trailer is other than CR and LF (0DH 0AH). 	<ul style="list-style-type: none"> Hardware interface error has occurred (flaming, overrun, parity). Mismatch of communication address. Data length of a frame is not 8-byte. Function code is other than 03H, 06H, or 08H. CRC operation result is different.

10-5. Communication data address list

The supported data addresses are listed in the following table.

- In the R/W column, R indicates that the data is supported by the Read command, W indicates that it is supported by the Write command, and R/W indicates that it is supported by the Read or the Write command.
- In the OP column, the data is supported when the following option is installed.
AL: Alarm output AOUT: Analog output DSP : color

address	Descriptions	R/W	OP	Note
0040H	Series code 1	R		SD, fixed
0041H	Series code 2	R		17, fixed
0042H	Series code 3	R		00, fixed
0043H	Series code 4	R		00, fixed
0044H	Software version No. code 1	R		
0045H	Software version No. code 2	R		
0100H	PV (process value)	R		Note 1
0103H	Reserved	R		
0104H	Action flag	R		Note 2
0105H	Alarm action flag	R	AL	Note 2
010DH	Alarm latching output flag	R	AL	Note 2
018CH	Communication code (0: LOC, 1: COM)	W		
0198H	Alarm latching release	W	AL	Note 2
033EH	Screen saver (0:OFF, 1:1 to 100)	R/W		
033FH	PV LED (0: RED, 1: WHIT)	R/W	DSP	
04FBH	PV LED of alarm output (0: NON, 1: CHG)	R/W	EV	
04FCH	PV LED Flashes on and off (0: OFF, 1: ON)	R/W	EV/DSP	
0500H	Alarm 1 code (0: non, 1: HA, 2: LA, 3: HA_L, 4: LA_L, 5: SO)	R/W	AL	
0501H	Alarm 1 setting value	R/W	AL	
0502H	Alarm 1 hysteresis	R/W	AL	
0503H	Alarm 1 inhibit (0: OFF, 1: ON)	R/W	AL	
0508H	Alarm 2 code (0: non, 1: HA, 2: LA, 3: HA_L, 4: LA_L, 5: SO)	R/W	AL	
0509H	Alarm 2 setting value	R/W	AL	
050AH	Alarm 2 hysteresis	R/W	AL	
050BH	Alarm 2 inhibit (0: OFF, 1: ON)	R/W	AL	
05A1H	Analog output scaling lower-limit value	R/W	AOUT	
05A2H	Analog output scaling higher-limit value	R/W	AOUT	
05B1H	Kind of communication mode (0:COM1, 1:COM2)	R/W		

address	Descriptions	R/W	OP	Note
0611H	Key lock (0: OFF, 1: ON)	R/W		
0701H	PV bias	R/W		
0702H	PV filter	R/W		
0703H	Reserved	R/W		
0704H	Input unit (0: °C, 1: °F)	R/W		
0705H	Measuring range	R/W		
0706H	Reserved	R/W		
0707H	Input scaling decimal places (0: without, 1: nnn.n, 2: nn.nn, 3:n.nnn)	R/W		
0708H	Input scaling lower-limit value	R/W		
0709H	Input scaling higher-limit value	R/W		
070AH	Decimal places (0: with, 1: without)	R/W		

Note 1 In case the abnormal measured value is detected:
 If **HHHH**, **CJHH**, or **b---** is displayed on the screen, 7FFFH is returned, and **LLLL** or **CJLL** is displayed, 8000H is returned.
 In case of standard protocol or MODBUS ASCII mode, 7FFFH is converted into 37H 46H 46H 46H, and 8000H is converted into 38H 30H 30H 30H.
 In case of MODBUS RTU mode, 7FFFH is converted into 7FH FFH, and 8000H is converted into 80H 00H.

Note 2 Each data is treated as bit data. Refer to the table below to know each bit sequence of data (When active, the bit=1, and when inactive, the bit=0)

Address	D15	D14	D13	D12	D11	D10	D9	D8	D7	D6	D5	D4	D3	D2	D1	D0
0104H								COM								
0105H															AL2	AL1
010DH															AL2	AL1
0198H															AL2	AL1

10-6. ASCII Code Table

	b7~b5	000	001	010	011	100	101	110	111
b4~b1		0	1	2	3	4	5	6	7
0000	0	NUL	TC7(DLE)	SP	0	@	P	`	p
0001	1	TC1(SOH)	DC1	!	1	A	Q	a	q
0010	2	TC2(STX)	DC2	"	2	B	R	b	r
0011	3	TC3(ETX)	DC3	#	3	C	S	c	s
0100	4	TC4(EOT)	DC4	\$	4	D	T	d	t
0101	5	TC5(ENQ)	TC8(NAK)	%	5	E	U	e	u
0110	6	TC6(ACK)	TC9(SYN)	&	6	F	V	f	v
0111	7	BEL	TC10(ETB)	'	7	G	W	g	w
1000	8	FE0(BS)	CAN	(8	H	X	h	x
1001	9	FE1(HT)	EM)	9	I	Y	i	y
1010	A	FE2(LF)	SUB	*	:	J	Z	j	z
1011	B	FE3(VT)	ESC	+	;	K	[k	{
1100	C	FE4(FF)	IS4(FS)	,	<	L	\	l	
1101	D	FE5(CR)	IS3(GS)	-	=	M]	m	}
1110	E	SO	IS2(RS)	.	>	N	^	n	~
1111	F	SI	IS1(US)	/	?	O	_	o	DEL

11. Specification

Display	
Digital display	Process value (PV), 11-segment, 4-digit red LED (approx..20mm character height) (Optional) 11-segment,4-digit white LED (approx..20mm character height)
Action indication	PL/SET (green): lit when parameter value is displayed ECO (green) : lit when screen-saver mode is set AL1/AL2 (red) : lit when alarm signal is output
Display accuracy	$\pm (0.3\%FS + 1 \text{ digit})$ within measuring range Excluding cold junction temperature compensation accuracy of thermocouple input. The accuracy of 400°C or below 752°F of thermocouple B is not guaranteed. Accuracy of thermocouple T or U is $\pm (0.5\%FS+1\text{digit})$ at above -100°C and 0°C or below, and $\pm (1\%FS+1\text{digit})$ at -100°C or below.
Display accuracy maintaining range	23°C \pm 5°C (18 - 28°C)
Display resolution	Differs depending on the measuring range (0.001, 0.01, 0.1, 1)
Measured value display range	-10 - 110% of measuring range (Accuracy is only guaranteed when the value is within the measuring range). For R.T.D. input of -199.9 - 600.0°C: -240.0 - 680.0°C -199.9 - 500.0°C: -240.0 - 570.0°C For thermocouple K of -199.9 - 800.0°C: -273.1 - 900.0°C
Display update cycle	0.25 - 5.00 secs (0.25 secs step) When 0.50 secs or more is set, a difference may occur among the displayed value, the analog output, and the communication data.

Setting	
Setting method	Using four key switches on the front panel Setting protection feature by key lock ON/OFF is provided.
Setting range	Same as the measuring range.

Input		
Input type	Thermocouple, R.T.D., voltage (mV/V). Universal-input	
Thermocouple	B, R, S, K, E, J, T, N {U, L (DIN43710)}, C(WRe5-26) For details, refer to the Measuring range code table.	
Lead wire tolerable resistance	100 Ω max.	
Input impedance	500k Ω min.	
Burnout	Standard feature (up-scale)	
Cold junction compensation accuracy	$\pm 1^\circ\text{C}$ (within accuracy maintain range (18 - 28°C)) $\pm 2^\circ\text{C}$ (ambient temperature 5 - 18°C, 28 - 45°C)	
R. T. D	JIS Pt100 3-wire type, JPt100 3-wire type	
Amperage	Approx. 0.25mA	
Lead wire tolerable resistance	5 Ω max./wire (each wire should have the same resistance)	
Voltage	mV	0 - 10mV DC
	V	0 - 5, 1 - 5, 0 - 10V DC
Current	4 - 20mA DC	
External receiving resistor	250 Ω (supplied if specified)	
Input scaling function	Available in case of voltage (mV/V) or current (mA) input. Reverse scaling can be set.	
Scaling range	-1999 - 9999 digit	
Span	10 - 10000 digit	
Decimal places	None, 0.0, 0.00, 0.000	
Sampling cycle	0.25 secs	
PV bias	-1999 - 2000	
PV filter	0 - 100 secs (PV filter is set to OFF when 0 sec)	
Isolation	Isolated between input and analog output (sensor power supply), or between input and communication. Not isolated between input and system.	

Alarm output (option)	
Number of alarm points	2 points (AL1 and AL2), normally open, COM is commonly used.
Alarm type	One of the following six types can be assigned to each alarm. None, higher-limit absolute value alarm (with latching), higher-limit absolute value alarm (without latching), lower-limit absolute value alarm (with latching), lower-limit absolute value alarm (without latching), Scale over
Setting range	Within measuring range or within scaling range
Alarm action	ON-OFF action
Hysteresis	1 - 999 digit
Inhibit action	ON/OFF can be selected for each alarm output.
Output type	Contact 1a (COM is commonly used)
Rating	240V AC 1.5A (resistive load)
Output update cycle	0.25 secs
Isolation	Isolated between alarm output and input, between alarm output and analog output (sensor power supply), between alarm output and communication, or between alarm output and system. Not isolated between alarm output 1 and alarm output 2.

Analog output (option)	
Analog output type	0 - 10mV (Output resistance 10 Ω) 0 - 10V (Load current 1mA max.) 4 - 20mA (Load resistance 300 Ω max.)
Output resolution	Approx. 1/14000
Output accuracy	$\pm 0.3\%$ FS of display value
Scaling	Within measuring range or within input scaling range (reverse scaling can be set).
Output update cycle	0.25 secs
Isolation	Isolated between analog output and input, between analog output and alarm output, between analog output and communication, or between analog output and system.

Sensor power supply (option)	
Output rating	24V \pm 3V DC 25mA max. Depending upon instrument's power ON-OFF status.
Isolation	Isolated between sensor power supply and input, between sensor power supply and alarm output, between sensor power supply and communication, or between sensor power supply and system.
Restrictions	Sensor power supply can't be selected when the analog output is selected. Sensor power supply can't be selected when the power supply 24V is selected.

Communication (option)	
Communication type	RS-232C, RS-485
Communication system	Half duplex asynchronous communication method
Communication speed	1200, 2400, 4800, 9600, 19200, 38400 bps
Data format	7E1, 7E2, 7N1, 7N2, 8E1, 8E2, 8N1, 8N2
Communication address	1 - 255
Number of connectable devices	31 devices max. (for RS-485)
Delay	1 - 100 msec
Communication protocol	Standard protocol, MODBUS ASCII, MODBUS RTU (start character and BCC operation method can be selected for standard protocol).
Isolation	Isolated between communication and input, between communication and alarm output, between communication and analog output (sensor power supply), or between communication and system.

Miscellaneous		
Data storage	By nonvolatile memory (EEPROM).	
Ambient conditions for use	Temperature	-10 - 50°C
	Humidity	90%RH max. (no dew condensation)
	Height	2000m above sea level or lower
	Over voltage category	II
	Degree of pollution	2 (IEC60664)
Power supply voltage (frequency)	100 - 240V AC \pm 10% (50/60Hz) 24V AC (50/60Hz) /DC \pm 10% (option)	
Power consumption	11VA (100 - 240V AC) 8VA (24V AC) 5W (24V DC)	
Applicable standard	Safety	IEC61010-1 and EN61010-1 EN IEC 61010-2-030
	EMC	EN61326-1
Dust proof /drip proof	IP66 equivalent (Panel thickness :1.2-3.2mm) Only front panel has dust-proof and drip-proof structure equivalent to IP66.	
Isolation resistance	Between input/output terminals and power terminal: 500V DC 20M Ω min. Between input/output terminals and ground terminal: 500V DC 20M Ω min.	
Dielectric strength	Between input/output terminals and power terminal: 3000V AC for one minute. Between power terminal and ground terminal: 1500V AC for one minute.	
Case material	Black PPE resin molding	
External dimensions	H48 x W96 x D111 mm (inside of panel: 100mm)	
Mounting	Push-in panel (one-touch mount)	
Panel thickness	1.0 - 4.0 mm	
Panel cutout	H45 x W92 mm	
Weight	Approx. 250g	

12. Warranty Policy

This product is warranted to be free from defects for one year from the date of delivery. If repair is required within this period, return the product to us on freight prepaid basis. Repairs will be performed free of charge if the defect is not due to misuse, force majeure, or transportation not arranged by us. The cause of defects shall be determined solely by us.

Out-of-warranty repairs are available for a fee upon request.

Kindly obtain authorization before returning the product.

For details, contact us or the retailer from which the product was purchased.

The contents of this manual are subject to change without notice.

SK SATO

Sato Keiryoki Mfg. Co., Ltd.

3-4, Kanda-kajicho, Chiyoda-ku, Tokyo 101-0045, Japan

<https://www.sksato.co.jp/en/>

Printed in Japan